

Industrial/Commercial Division
The Fulton Companies

 **Fulton**[®]
www.fulton.com

Fulton FB-A, FB-B Fuel-Fired Vertical Steam and Hot Water Boilers

FB-A . . . 4-150HP
FB-B . . . 4-150HP

Built/Certified in Accordance to ASME
Boiler and Pressure Vessel Code



The Fulton Companies is
a TÜV certified ISO9001
company.

Fulton vertical fuel-fired steam and hot water boiler

For over 60 years the Fulton vertical tubeless boilers have remained a compact trouble-free boiler supplying steam and hot water to virtually every type of industry imaginable.

The Classic efficient FB-A, FB-B Fulton boilers are available in 13 sizes ranging from 4 to 150 BHP.

Simplicity and reliability offer years of trouble-free operation. With no tubes or coils to scale up, rust or burn out, a Fulton Boiler reduces plant operating costs by eliminating down time and expensive repairs.

All Fulton Boilers feature the Fulton designed top mounted down-fired standard power burner or new optional low emissions burner. The velocity of the premixed air and gas reduces the residence time in the low emissions burner. Due to this high velocity gas/air mixture, Fulton's burners are capable of maintaining NOx concentrations below 20 PPM and 60 PPM CO corrected to 3% O₂. The Fulton Low Emissions Burner is also under 20 ng NOx/joule output.



FBA-050 gas-fired steam boiler, FBA-030 oil-fired steam boiler and FBA-100 oil-fired steam boiler (left to right)

Fulton Engineers/Manufactures Total System for Industrial Process Applications

Fulton, involved in engineering total systems to meet the needs of a specific application has been manufacturing steam boilers for over 60 years. Fulton's engineering, drafting, and manufacturing capabilities can build just about anything around a customer's needs. Fulton's custom built, factory skid mounted and pre-piped equipment save a tremendous amount of time and work on the job site.



Custom skid mounted boiler and accessories



The Fulton Classic FB-A, FB-B boilers can be ordered with combination oil and gas capabilities or be converted at any time simply and economically.

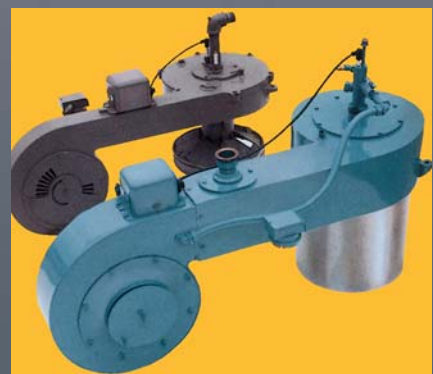

Standard top-mounted down-fired burner (back) and low emission burner (front)

Component View/Features of the vertical tubeless boiler (4-60BHP.)

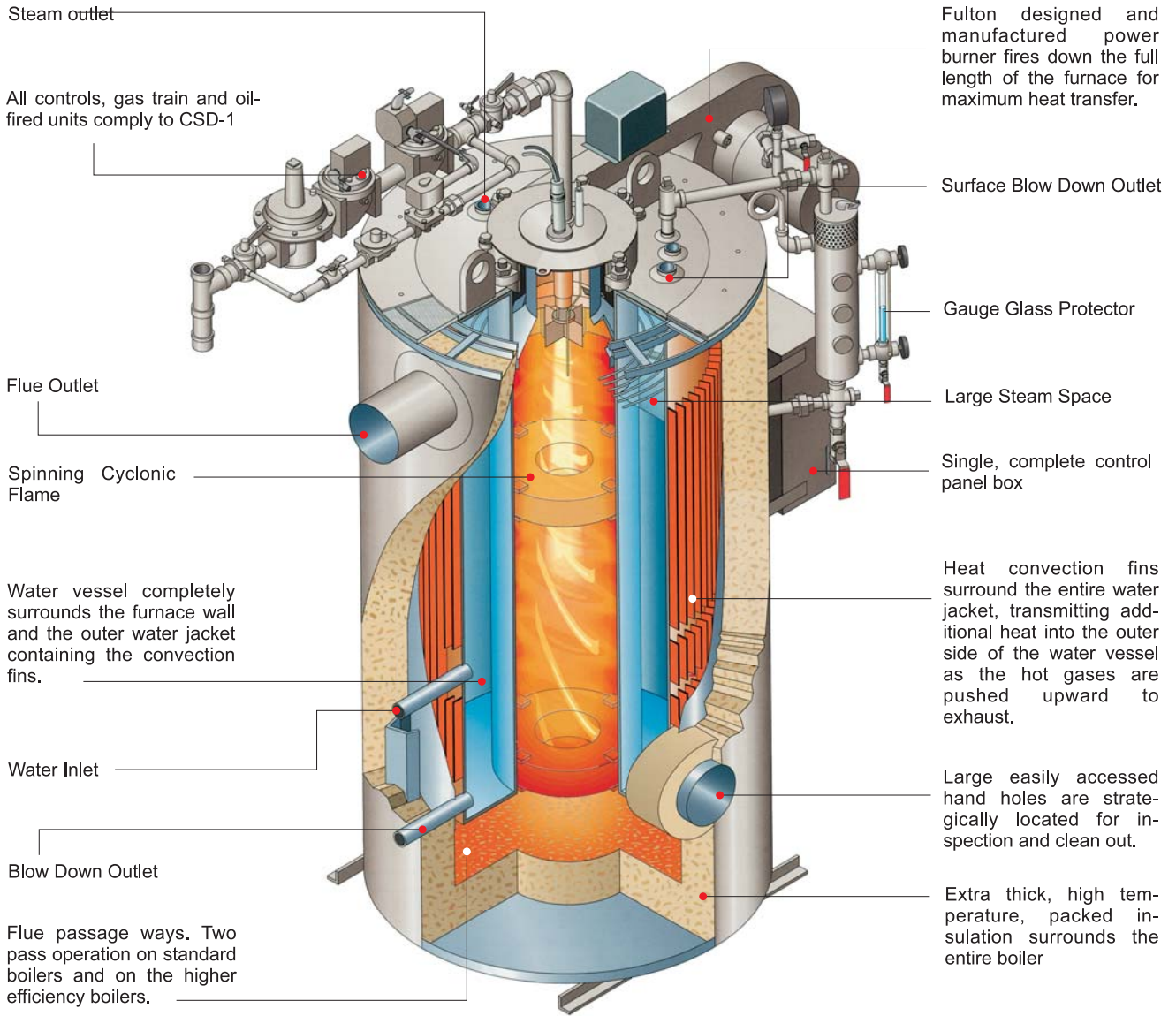

The Fulton Difference

Pipe Within a Pipe

The furnace (Pressure vessel) is, simply stated, a "pipe within a pipe." The top mounted burner sends a spinning, cyclonic flame down the center furnace chamber. The hot gases return upward in the secondary flue passage, traveling over the heat convection fins. These fins transmit the remaining heat onto the outer side of the water vessel. This results in the most uniform overall heating of the boiler, maximizing the pressure vessel's longevity.



Component View/Features of the VMP Design in 80-150 BHP

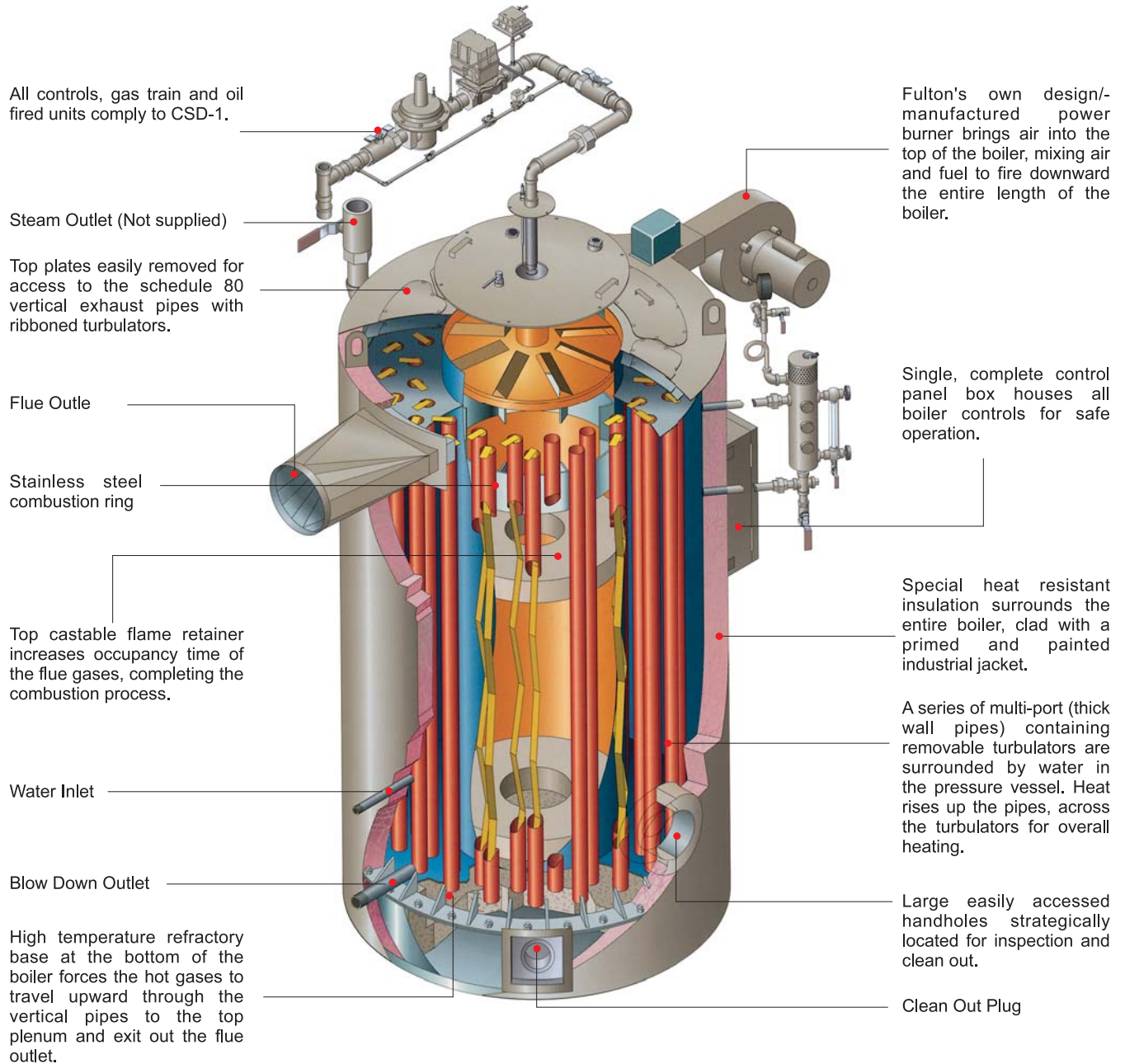

The Fulton Difference

Pipe vs. Tube

Sixty years after creating the vertical tubeless category of boilers, Fulton has introduced another innovation—the Pipetype Boiler. Constructed of Schedule 80, heavy wall pipes replacement is a thing of the past. This simple design is proven by decades of experience, and is backed by our unmatched warranty. See the difference there or call us for physical sample of our “Pipe vs. Tube”.



Fulton vertical fuel-fired steam and hot water boiler

Specifications/Steam boiler

Model FB-A	4	6	10	15	20	30	40	50	60	80	100	130	150	
Ratings (sea level to 3000ft.)														
Steam out put	LB/HR	138	207	345	518	690	1035	1380	1725	2070	2760	3450	4484	5175
	KG/HR	63	94	157	235	312	470	627	783	939	1252	1565	2034	2348
Approximate Fuel Consumption at Rated Capacity														
Light oil	KG/HR	3.77	5.65	9.42	14.71	18.91	29.07	38.41	48.80	58.14	76.10	91.31	121.75	140.55
Propane Gas	M ³ / HR	1.88	2.81	4.69	7.32	9.41	14.47	19.12	24.29	28.94	37.88	45.45	60.61	69.97
Natural Gas	M ³ /HR	4.74	7.11	11.85	18.51	23.79	36.58	48.34	61.41	73.16	95.76	114.91	153.22	176.87
Town Gas	M ³ / HR	12.06	18.09	30.14	47.06	60.50	93.02	122.92	156.15	186.05	243.51	292.21	358.61	413.97
Natural Gas Boiler	IN	1	1	1	1	1.25	1.5	1.5	1.5	2	2.5	3	3	3
Connection Size	MM	25	25	25	25	32	38	38	38	50	64	76	76	76
Burner	3450 RPM/60CY					GAS OIL	GAS OIL	GAS OIL	GAS OIL	GAS OIL	GAS OIL	GAS OIL	GAS OIL	GAS OIL
Motor HP	2850 RPM/50CY	1/3	1/3	1/3	1/3	1/3 3/4	1/3 3/4	1 1/2 2	1 1/2 2	1 1/2 2	2 3	3 3	4 4	4 4
Electric Power Requirements (in Amps)														
380V/50HZ	3Phase	0.9	0.9	0.9	0.9	0.9 1.4	0.9 1.4	2.6 3.7	2.6 3.7	2.6 3.7	3.7 4.6	4.6 4.6	6.2 6.2	6.2 6.2
Control voltage		2	2	2	2	2	2	2	2	2	2	2	2	2
220V/50HZ/1 Phase														

Note: High pressure boilers ordered with an extra pressure control for night heating have less than rated output while operating at low pressure.

Specifications/Hot water boiler

Model FB-B	4	6	10	15	20	30	40	50	60	80	100	130	150	
Ratings (Sea Level to 3000 ft)														
Output	1000BTU/HR	136	205	341	512	682	1023	1365	1706	2047	2729	3412	4435	5117
	1000KCAL/HR	34.4	51.6	86.0	129.0	172.0	258.0	344.0	430.0	516.0	688.0	860.0	1118.0	1290.0
Hot water OUTPUT(30°C difference)		1147	1720	2867	4300	5733	8600	11467	14333	17200	22933	28667	37267	43000
Approximate Fuel Consumption at Rated Capacity														
Light oil	KG/HR	3.70	5.55	9.25	13.09	17.45	26.18	34.90	43.63	52.35	68.25	85.32	110.91	126.57
Propane Gas	M ³ / HR	1.84	2.76	4.61	6.52	8.69	13.03	17.37	21.72	26.06	33.98	42.47	55.21	63.00
Natural Gas	M ³ / HR	4.66	6.99	11.64	16.47	21.96	32.94	43.92	54.90	65.88	85.89	107.37	139.58	159.28
Town Gas	M ³ / HR	11.84	17.76	29.60	41.88	55.84	83.77	111.69	139.61	167.53	218.41	273.02	354.92	405.02
Natural Gas Boiler	IN	1	1	1	1	1.25	1.5	1.5	1.5	2	2.5	3	3	3
Connection Size	MM	25	25	25	25	32	38	38	38	50	64	76	76	76
Burner	3450 RPM/60CY					GAS OIL	GAS OIL	GAS OIL	GAS OIL	GAS OIL	GAS OIL	GAS OIL	GAS OIL	GAS OIL
Motor HP	2850 RPM/50CY	1/3	1/3	1/3	1/3	1/3 3/4	1/3 3/4	1 1/2 2	1 1/2 2	1 1/2 2	2 3	2 3	4 5	4 5
Electric Power Requirements (in Amps)														
380V/50HZ	3Phase	0.9	0.9	0.9	0.9	0.9 1.4	0.9 1.4	2.6 3.7	2.6 3.7	2.6 3.7	3.7 4.6	3.7 4.6	6.2 8	6.2 8
Control voltage		2	2	2	2	2	2	2	2	2	2	2	2	2
220V/50HZ/1 Phase														

Note: Fuel consumption based on: light oil 11200 kcal/kg, Natural gas 8900kcal/ m³, Propane gas 22500kcal/ m³, Town gas 3500kcal/ m³. Specifications are approximate. We reserve the right to change specifications.

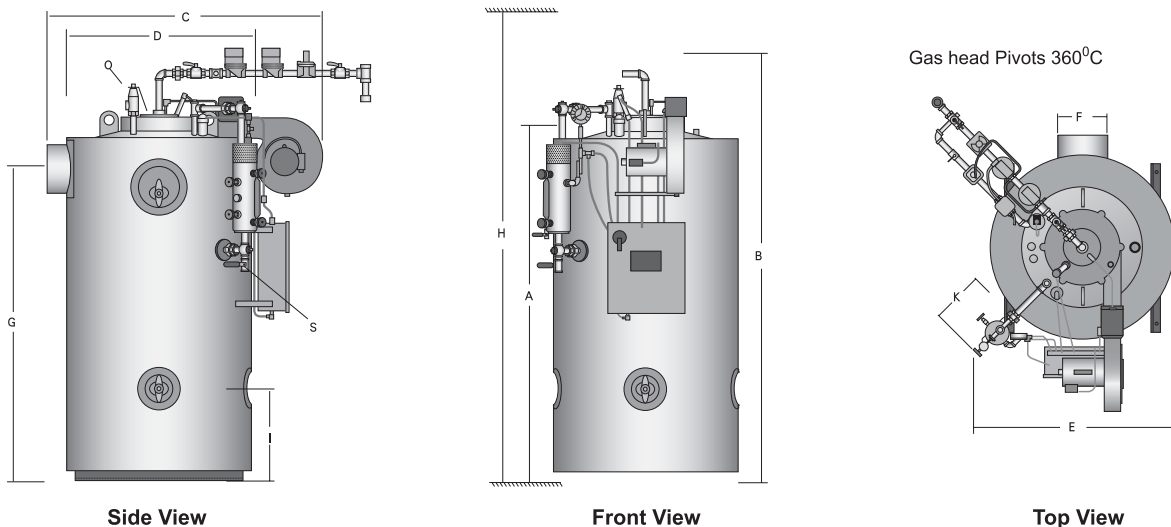

FB-A/FB-B (4-60BHP)

Dimensions and Weights FB-A, FB-B are approximately the same.

Model FB-A, FB-B		4	6	10	15	20	30	40	50	60	80	100	130	150
Heights and widths														
A Boiler Height	IN	47	57	63	69	72	82	73.5	87	93	93	99	117	117
	MM	1194	1448	1600	1753	1829	2083	1867	2210	2362	2362	2515	2889	2972
B Boiler Height With Trim & Fuel Train Assembly	IN	65	75	80.5	86.5	92.5	102	94	106.5	120	122	125	135	141
	MM	1651	1905	2045	2197	2350	2591	2388	2705	3048	3099	3175	3430	3582
C Overall Depth Stack To Burner Fan Housing	IN	44	44	46	47	60	67	73	78	78	90	120	134	136
	MM	1118	1118	1168	1194	1524	1702	1854	1981	1981	2280	3043	3395	3455
D Boiler Diameter	IN	26	26	28	30	39	46	55	55	55	63	68	76	76.5
	MM	660	660	710	760	990	1170	1400	1400	1400	1588	1740	1936	1943
E Overall Width With Water Column	IN	33	33	33.5	35.5	43	49	57	57	57	67	75	83	84.5
	MM	838	838	851	902	1091	1244	1448	1448	1448	1702	1905	2108	2146
F Flue Outlet Diameter	IN	6	6	6	8	10	12	12	12	12	14	14	16	16
	MM	152	152	152	203	254	305	305	305	305	356	356	400	407
G To Center of Flue Outlet	IN	42	52	58	63	66	73.5	63	79	85	95	95	107	110
	MM	1070	1320	1473	1600	1675	1867	1606	2007	2195	2423	2423	2723	2794
Minimum Clearance														
H Clearance Required for Burner Removed from Ceiling to Ground	IN	72	82	86	92	96	106	106	114	124	126	129	151	157
	MM	1828	2083	2184	2337	2438	2692	2692	2896	3150	3200	3277	3835	3988
Boiler Front	IN	41	41	41	41	41	41	41	41	41	41	41	41	41
	MM	1041	1041	1041	1041	1041	1041	1041	1041	1041	1041	1041	1041	1041
Boiler Back/Side	IN	36	36	36	36	36	36	36	36	36	36	36	36	36
	MM	915	915	915	915	915	915	915	915	915	915	915	915	915
Water Content														
	US.GAL	14	16	24	39	77	170	220	245	270	375	580	876	904
	LITERS	53	61	91	148	292	643	835	927	1022	1419	2195	3317	3423
Weight														
Gross Shipping Weight	LB	1400	1700	2000	2280	3400	4780	6400	6526	7280	10506	11608	15418	15550
	KG	640	770	910	1035	1545	2170	2905	2963	3305	4770	5270	7000	7060

Note: Specifications are approximate. We reserve right to change specifications.

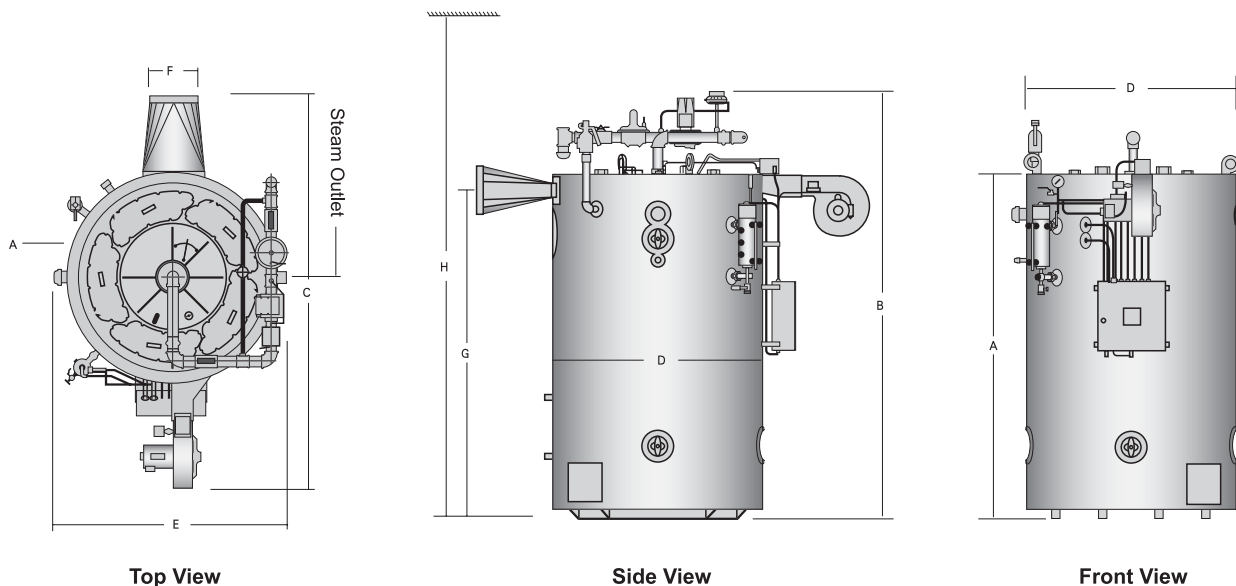

FB-A/FB-B (80-150HP)



Polished Stainless Jacket

A relatively inexpensive option for the customer who requires a smart look. No matter if it's a stainless jacket or a complete skid-mounted unit(s) with boiler, return system, blowdown, and any other special equipment, Fulton can build to any industrial process application.

Fulton Warranty No.1 in the Industry!

All Fulton Boilers are completely trimmed packaged boilers. No additional fuel train items or electrical wiring is needed. Boiler is supplied with installation manual, ready for quick installation by the Fulton representative.



5 Year (60 Month) Full Warranty*
 On the Fulton Boiler Pressure Vessel

Fulton *Fulton Boiler Works*



The Fulton Companies
 972 Centerville Road
 Pulaski, NY USA 13142
 Phone:(315)298-5121
 Fax:(315)298-6390
 www.fulton.com

Fulton China LLC
 No.9 18th Streets
 HETZ Hangzhou China 310018
 Phone:(86)571-86725890
 Fax:(86)571-86725896
 www.fulton.cn

Sales Representative

Fulton China LLC is part of the Fulton Companies manufactures high grade industrial/commercial heat transfer products